



## SunPower X-Series: X21-470-COM

# SunPower® Commercial DC Panel

SunPower X-Series panels combine the top efficiency, durability and warranty available in the market today, resulting in more long-term energy and savings. <sup>1,2</sup>



### Maximum Power. Minimalist Design.

Generates more power and savings per available space, making it easier to meet your organization's goals.



### Highest Lifetime Energy and Savings

Designed to deliver 60% more energy in the same space over 25 years in real-world conditions like partial shade and high temperatures. <sup>2</sup>

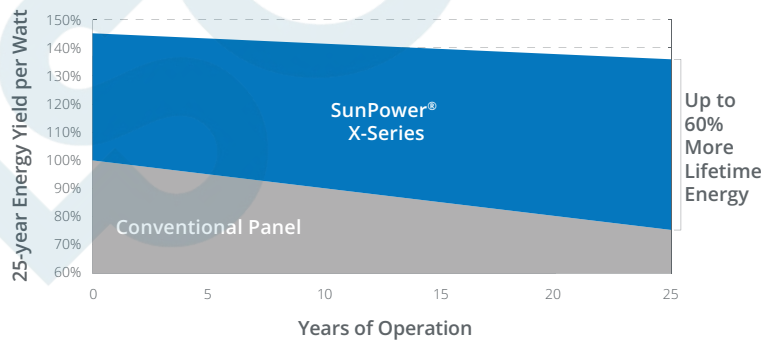

## Fundamentally Different. And Better.

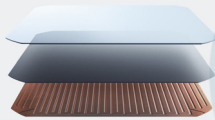

### The SunPower Maxeon® Solar Cell

- Enables highest efficiency panels available <sup>2</sup>
- Unmatched reliability <sup>3</sup>
- Patented solid metal foundation prevents breakage and corrosion



### As Sustainable As Its Energy

- Ranked #1 in Silicon Valley Toxics Coalition 2015 Solar Scorecard <sup>4</sup>
- First solar panels to achieve Cradle to Cradle Certified™ Silver recognition <sup>5</sup>
- Contributes to more LEED categories than conventional panels <sup>6</sup>



### Best Reliability, Best Warranty

With more than 25 million panels deployed around the world, SunPower technology is proven to last. That's why we stand behind our panel with the industry's best 25-year Combined Power and Product Warranty, including the highest Power Warranty in solar.

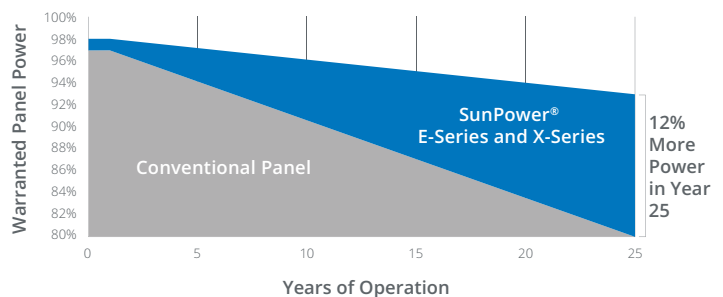

## X-Series: X21-470-COM SunPower® Commercial DC Panel

Electrical Data		
	SPR-X21-470-COM	SPR-X21-460-COM
Nominal Power (P <sub>nom</sub> ) <sup>7</sup>	470 W	460 W
Power Tolerance	+5/0%	+5/0%
Panel Efficiency	21.7%	21.3%
Rated Voltage (V <sub>mpp</sub> )	77.6 V	77.3 V
Rated Current (I <sub>mpp</sub> )	6.06 A	5.95 A
Open-Circuit Voltage (V <sub>oc</sub> )	91.5 V	90.5 V
Short-Circuit Current (I <sub>sc</sub> )	6.45 A	6.39 A
Max. System Voltage	1000 V UL & 1000 V IEC	
Maximum Series Fuse	15 A	
Power Temp Coef.	-0.29% / °C	
Voltage Temp Coef.	-223.2 mV / °C	
Current Temp Coef.	2.9 mA / °C	

Tests And Certifications	
Standard Tests <sup>8</sup>	UL1703 (Type 2 Fire Rating), IEC 61215, IEC 61730
Quality Management Certs	ISO 9001:2015, ISO 14001:2015
EHS Compliance	RoHS, OHSAS 18001:2007, lead free, Recycle Scheme, REACH SVHC-163
Sustainability	Cradle to Cradle Certified™ Silver. "Declare." listed.
Ammonia Test	IEC 62716
Desert Test	10.1109/PVSC.2013.6744437
Salt Spray Test	IEC 61701 (maximum severity)
PID Test	1000 V: IEC 62804, PVEL 600 hr duration
Available Listings	UL, TUV, MCS, FSEC, CEC

Operating Condition And Mechanical Data	
Temperature	-40° F to +185° F (-40° C to +85° C)
Impact Resistance	1 inch (25 mm) diameter hail at 52 mph (23 m/s)
Appearance	Class A
Solar Cells	128 Monocrystalline Moxeon Gen III
Tempered Glass	High-transmission tempered anti-reflective
Junction Box	IP-65, 1230 mm cables / MC4 Compatible
Weight	56 lbs (25.4 kg)
Max. Load	Wind: 50 psf, 2400 Pa, 244 kg/m <sup>2</sup> front & back Snow: 112 psf, 5400 Pa, 550 kg/m <sup>2</sup> front
Frame	Class 2 silver anodized; stacking pins

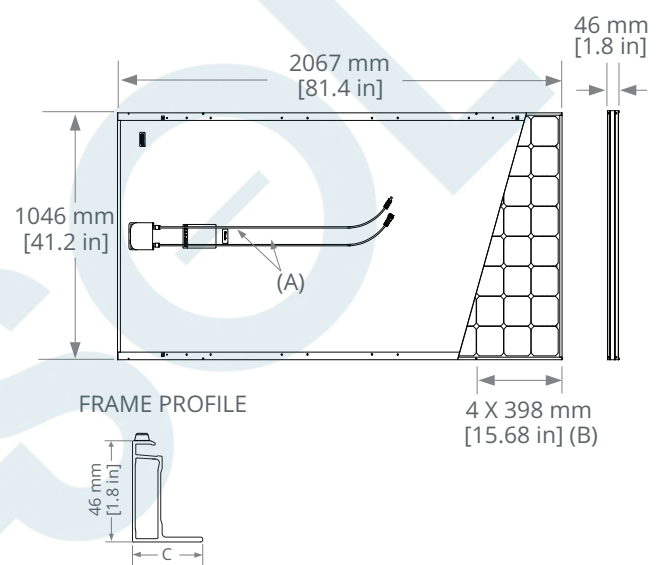

- (A) Cable Length: 1230 mm +/- 10 mm  
 (B) Stacking Pins  
 (C) Long Side: 32 mm [1.3 in]  
 Short Side: 22 mm [0.9 in]

Please read the safety and installation guide.

1 SunPower 360 W compared to a Conventional Panel on same-sized arrays (260 W, 16% efficient, approx. 1.6 m<sup>2</sup>), 4% more energy per watt (based on PVsyst pan files), 0.75%/yr slower degradation (Campeau, Z. et al. "SunPower Module Degradation Rate," SunPower white paper, 2013).

2 Based on search of datasheet values from websites of top 10 manufacturers per IHS, as of January 2017.

3 #1 rank in "Fraunhofer PV Durability Initiative for Solar Modules: Part 3". PVTech Power Magazine, 2015. Campeau, Z. et al. "SunPower Module Degradation Rate," SunPower white paper, 2013.

4 SunPower is rated #1 on Silicon Valley Toxics Coalition's Solar Scorecard.

5 Cradle Certified is a multi-attribute certification program that assesses products and materials for safety to human and environmental health, design for future use cycles, and sustainable manufacturing.

6 X-Series and E-Series panels additionally contribute to LEED Materials and Resources credit categories.

7 Standard Test Conditions (1000 W/m<sup>2</sup> irradiance, AM 1.5, 25° C). NREL calibration Standard: SOMS current, LACCS FF and Voltage.

8 Type 2 fire rating per UL1703:2013, Class C fire rating per UL1703:2002.

See [www.sunpower.com/company](http://www.sunpower.com/company) for more reference information. For more details, see extended datasheet: [www.sunpower.com/solar-resources](http://www.sunpower.com/solar-resources). Specifications included in this datasheet are subject to change without notice.

©2018 SunPower Corporation. All rights reserved. SUNPOWER, the SUNPOWER logo and MAXEON are trademarks or registered trademarks of SunPower Corporation. Specifications included in this datasheet are subject to change without notice.

**SOLSOL**

SOLSOL s.r.o.  
 Králova 298/4  
 Brno 616 00  
 Czech Republic  
 Tel: +420 773 576 737  
 E-mail: [sales@solsol.cz](mailto:sales@solsol.cz)  
[www.solsol.cz](http://www.solsol.cz)

**SUNPOWER®**