



ENERGY METER



DDSU666 5(80)A
DTSU666 5(80)A
DDSU666-CT 200A/5A
DTSU666-CT 200A/5A

Features

Accurate

- Class 1 measurement accuracy

Convenience

- Optional 35mm DIN rail or front mounting

Energy Saving

- Overall power consumption ≤ 1 W

Safe & Reliable

- Fuse-free design for superior safety
- International authoritative certification, more reliable
- Natural cooling fully sealed design for better reliability

Smart Energy

- Use clean, efficient renewable energy without pollution.
- Green and low carbon, saving economy, sustainable development

Smart Monitoring

- One terminal can control multiple devices, and perform parameter monitoring and fault query

For more information, please contact us

www.solaxpower.com

AU: +61 1300 476529

DE: +49 6142 4091664

Global: +86 571-56260008

UK: +44 2476 586998

NL: +31 (0) 852 737932

info@solaxpower.com
service@solaxpower.com





DDSU666
5(80)A



DTSU666
5(80)A



DDSU666-CT
200A/5A



DTSU666-CT
200A/5A

General Data				
Dimension (H xW xD)	100 x 36 x 65.5 mm (3.9 x 1.4 x 2.6 inch)	100 x 72 x 65.5 mm (3.9 x 2.8 x 2.6 inch)	100 x 36 x 65.5 mm (3.9 x 1.4 x 2.6 inch)	100 x 72 x 65.5 mm (3.9 x 2.8 x 2.6 inch)
Mounting type	DIN35 Rail			
Weight (including cables)	1.2 kg (2.6 lb)	1.5 kg (3.3 lb)	1.2 kg (2.6 lb)	1.5 kg (3.3 lb)
Power Supply				
Power grid type	1P2W	3P4W/3P3W	1P2W	3P4W/3P3W
Input voltage (phase voltage)	184Vac ~ 264.5Vac	154 Vac ~ 286 Vac	184Vac ~ 264.5Vac	154 Vac ~ 286 Vac
Power consumption	≤1 W	≤1.5 W	≤1 W	≤1.5 W
Measurement Range				
Line voltage	/	290.5 Vac~ 539.5 Vac	/	290.5 Vac~ 539.5 Vac
Phase voltage	184Vac ~ 264.5Vac	168 Vac ~ 312 Vac	184Vac ~ 264.5Vac	168 Vac ~ 312 Vac
Current	0.25-5(80)A	0.25-5(80)A	0.015-1.5(6)A (CT: 200A)	0.015-1.5(6)A (CT: 200A)
Measurement Accuracy				
Accuracy Class	Class B	Class B	Class C	Class C
Communication				
Interface	RS485			
Baud rate	9,600 bps			
Communication protocol	Modbus-RTU			
Environment				
Operating temperature range	-25°C~+55°C	-10°C~+45°C	-25°C~+55°C	-10°C~+45°C
Storage temperature range	-25°C~+55°C	-25°C~+75°C	-25°C~+55°C	-25°C~+75°C
Operating humidity	<75 % non condensing			
Others				
Accessories	/	RS485 Cable (10 m / 33 ft.), RJ45 connector	1 CT 200A/5A (1m)	3 CT 200A/5A (1m)

Solutions

DC — AC — RS485 — Internet

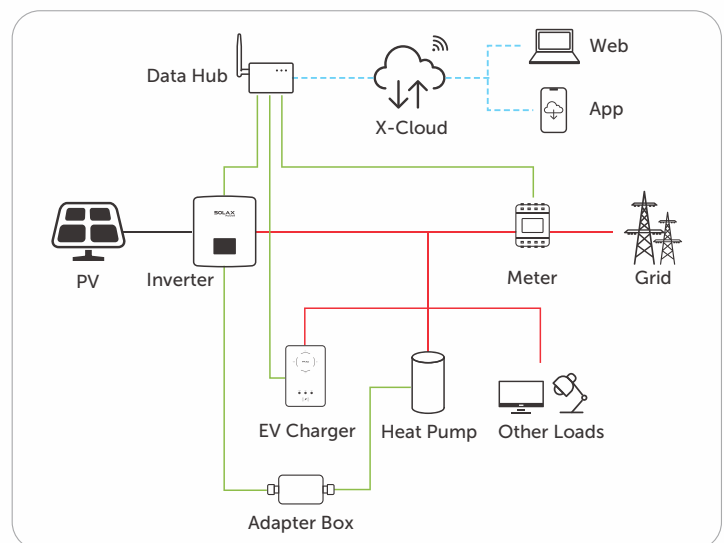
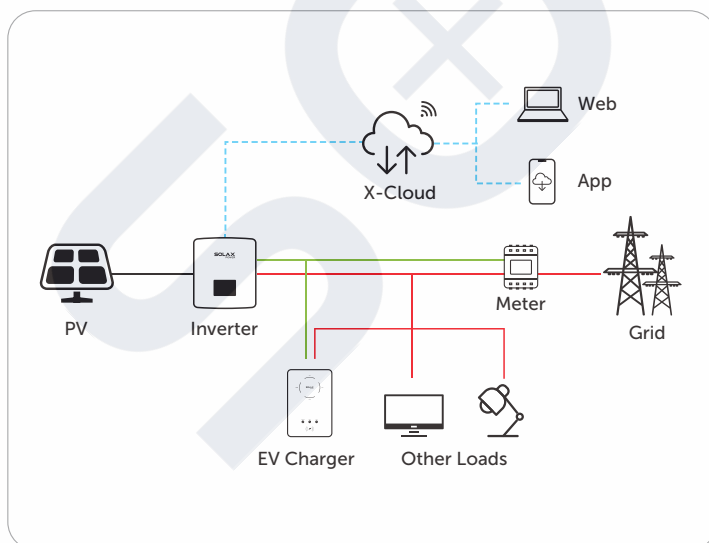

CT Optional

Model	LCTA97C2	LCTA97C4	ESCT-B812
Ratio	200A/5A	600A/5A	1500A/5A